

Ex LOUDSPEAKER/FLASHING LIGHT COMBINATION

BExCL 15-05D



Combination device for visual and acoustic alarms

- extremely intensive light reflection due to 5 joules xenon flash
- synchronised flash frequency or alternating flash mode in system operation
- acoustic and visual signal can be controlled separately
- highly resistant to corrosion and suitable for the toughest environments
- adjustable volume
- stainless steel protective cage and stainless steel mounting bracket for 360° positioning



max. covering distance



Protection system



Operating temperature

Electrical data	BExCL 15-05D				
Rated voltage	230 V AC	115 V AC	48 V DC	24 V DC	12 V DC
Rated frequency	50 / 60 Hz	50 / 60 Hz			
Operating range	± 10%	± 10%	42 – 54 V	20 – 28 V	10 – 14 V
Nominal current consumption	55 mA	140 mA	180 mA	270 mA	750 mA

Mechanical data	BExCL 15-05D	
Explosion protection	II 2G Ex d IIB T4	
Category (area of use)	2G (Zone 1) / 3G (Zone 2)	
Certificate of conformity	KEMA 03 ATEX 2545	
Testing body	KEMA	
Sound pressure level	113 dB (A) ± 3 dB (A) @ 15 W	
Rated power	sine wave	15 W
Transformer	type	100 V power – 15 W / 7.5 W / 3 W / 1 W taps (Z = 666.87 Ω / 1.34 kΩ / 3.34 kΩ / 10 kΩ)
Impedance	type	8 Ω or 16 Ω
Dispersion	120° @ 1 kHz / 32° @ 4 kHz	
Frequency range	400 Hz – 8,000 Hz	
Flash energy	5 J	
Flash rate	approx. 1 Hz	
Lens colours	clear, yellow, amber, red, green, blue	
Temperature class T	IIB: T4 @ - 50 °C ... + 70 °C Ta	
Storage temperature	- 50 °C ... + 70 °C	
Protection system according to EN 60529	IP 67	
Duty cycle	100%	
Service life of the flash tube	light emission still 70% after 8,000,000 flashes	
Material	lens	glass
	housing	die-cast aluminium LM6, RAL 3000 (flame red)
	horn	ABS self-extinguishing, similar UL 94 VO & 5VA FR ABS, Ex II 2D anti-static ABS
Connecting terminals	0.5 ... 4.0 mm ²	
Cable entry	2 / 1 x closed, 1 x open (M20), optionally PG13.5 or 1/2" NPT	
Weight	5 kg	

Dimensions

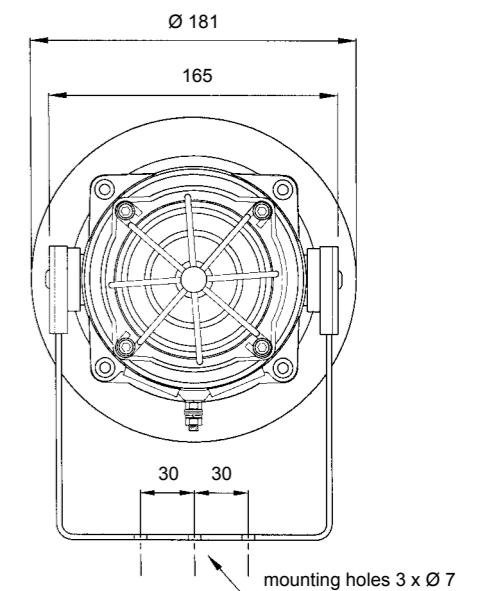
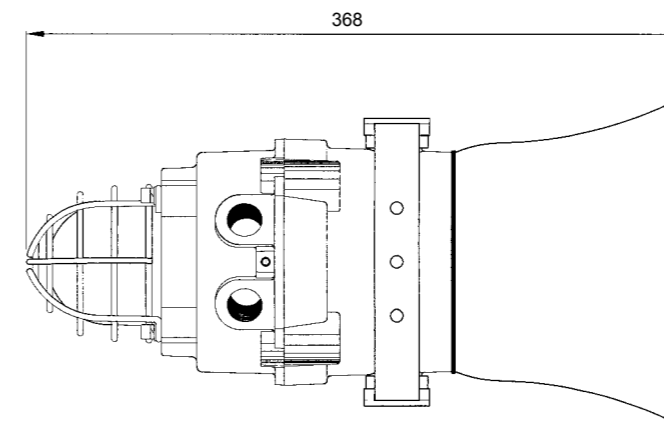

Ordering details

Article numbers		BExCL 15-05D	
Lens colour	Version	230 V AC	24 V DC
red	8 Ω	320 91 10 5 910	320 91 80 5 910
red	16 Ω	320 91 10 5 911	320 91 80 5 911
red	100 V transformer	320 91 10 5 912	320 91 80 5 912

Article numbers for other colours and voltages on request

Options / Accessories



Manufacturer's declaration

We hereby declare that the explosion-protected means of alarm with the type designation **BExCL 150-05 D** has been developed and manufactured in accordance with section 5.1.2 of EN 50014.

This declaration is based on compliance with the following regulations and standards:

94/9/EG	CE conformity
EN 50014	Electrical equipment for areas at risk of explosions – General requirements
EN 50018	Pressure-resistant encapsulation 'd'
EN 50281-1-1	Electrical equipment for use in areas with combustible dust